

MT-500

Transport robot



The mobile transport robot MT-500 was developed to rationalise the material transport within a production plant.

The MT-500 can drive up to 1.5 m/s and carry loads up to 80 kg. The platform is built with maintenance-free, robust mechanics and well-engineered electronics, featuring protection class IP 63. With its freely and easy programmable transport routes, the mobile transport robot MT-500 can be quickly re-installed when working conditions change.

The transport robot navigates by using natural landmarks in the environment. At time of installation, the MT-500 will be controlled by joystick to run through the working area, allowing the laser scanner at the front of the platform to detect the landmarks. A map of the area is then created from these landmarks. Work stations and transport routes can later be defined within this map. If the area has less distinguished marks, e.g. without visible walls and pillars, reflector marks are placed on suitable spots to help the robot determine its position.

Destination points can be defined either manually with the integrated keypad or via a network-capable command interface with open protocol. The graphical user interface allows comfortable operation, configuration and diagnosis.

NEOBOTIX

MT-500

Transport robot

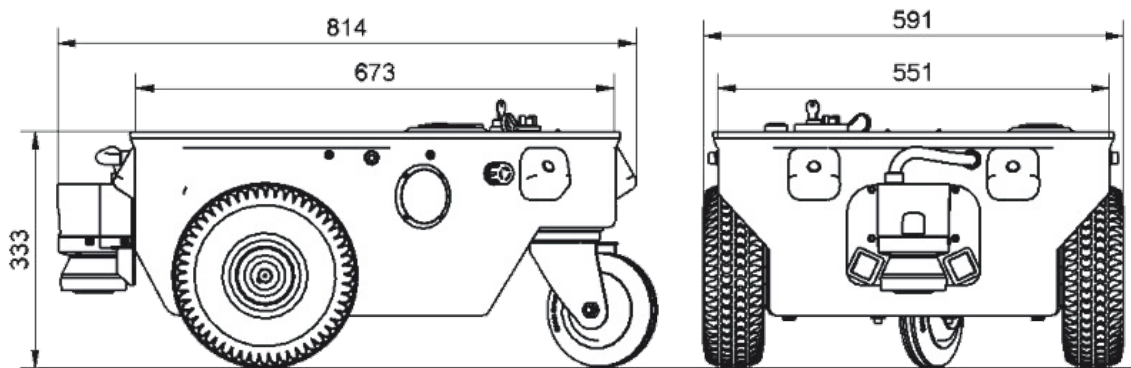

Technical data

Dimension	814 x 591 x 333 (LxWxH)
Weight	Platform weight: approx. 80 kg / payload: approx. 80 kg
Drive system	Differential kinematics, 2 maintenance-free servomotors with precision gearboxes
Platform speed	1.5 m/s
Battery capacity	approx. 10h
Sensors	1 x 2D laser scanner, 5 x ultrasonic sensors
Control	External PC (WLAN), on-board computer (keypad, LCD)
Options	Manipulator, tray system, material transfer, ...

NEOBOTIX