

# mobile manipulator MM-KR16

## Introduction

A mobile manipulator combines a manipulator arm with an autonomously moveable base. With MM-KR16 Neobotix offers the first industrial quality mobile manipulator comprised a standard Kuka KR16KS manipulator and a Neobotix differential wheel base. It is possible to move platform and arm independently or to synchronize motion of both. The arm is fully operational even if the platform moves. Industrial tasks that a mobile manipulator MM-KR16 can perform:

- assembly preparation: the mobile manipulator picks goods from boxes and transports it to further processing
- material flow: feeding machines with semifinished parts, e. g. milling machines
- welding of long weld seams
- spray painting of large structures
- inspection of large structures

## Mobile base

The mobile base computes its own position absolutely in space without the need to modify the environment. It uses two safety approved SICK laser scanners S300 with 360° view around the platform to acquire environment data and compare it to an internal map.

A large battery pack guarantees at least 10 hours of autonomous operation of manipulator and base. If discharged the battery pack can easily be replaced through the platform's front door. Using the integrated battery charger, to charge battery simply connect the platform to 220Vac.

A SICK safety control evaluates emergency stop and scanner data. Four different safety areas can be defined by software and activated dynamically at runtime.

The platform features two motorized wheels in differential arrangement with high quality brushless motors and backlash free gearings and two castor wheels.

Optional equipment includes

- ultrasonic sensors for collision avoidance (see product information sheet USBoardAutomotive)
- board for digital input/ output control (see product information sheet IOBoard)

## Manipulator

The manipulator is a standard Kuka KR16KS with 16 kg payload. Only the motors were replaced by servo drives with absolute encoders. Optional equipment for the arm are safety bumpers placed at joint 2 and at the wrist.

For a product information sheet please refer to [www.kuka-robotics.com](http://www.kuka-robotics.com).



# NEOBOTIX

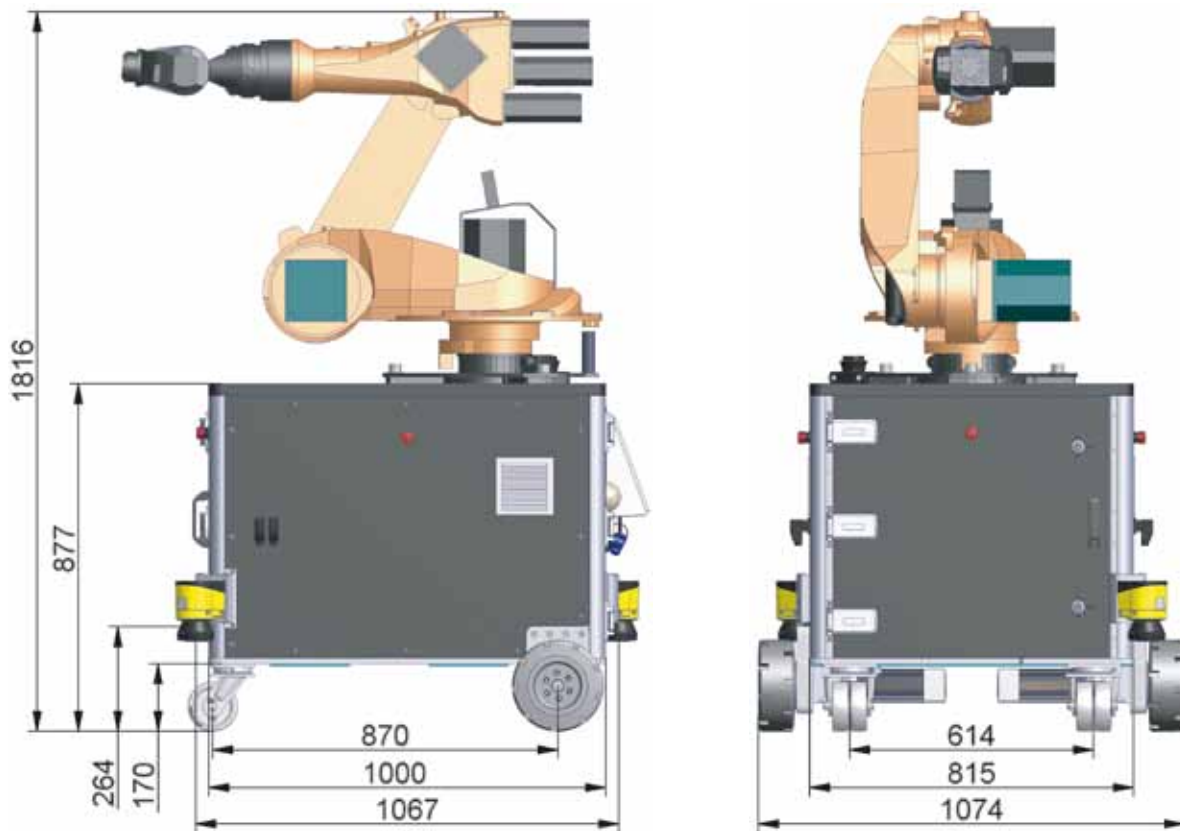

## Technical Data

platform speed	translational < 1 m/s, rotational < 90°/s
battery capacity	10 hours autonomous motion of platform and manipulator
manipulator payload	16 kg
manipulator speed	A1 < 120°/s A2 < 90°/s A3 < 120°/s A4, A5, A6 < 120°/s
safety system	SICK safety control Flexisoft 2 x SICK laser scanners multiple emergency stop buttons bumpers on arm
control software	platform: Neobotix <i>PlatformControl</i> manipulator: Neobotix <i>ArmControl</i>

**NEOBOTIX**